



# ENVIROPEEL SLUGGER 170

PORTABLE THERMOPLASTIC ANTI-CORROSION SPRAY APPLICATOR

## OPERATING INSTRUCTIONS

**PLEASE READ CAREFULLY BEFORE  
ATTEMPTING OPERATION**

230 volt & 120 volt versions



Electromagnetic Compatibility Directive  
(EM Q) 89/336/EEC  
Medical Equipment Directive  
(W Q) 73/23/EEC

Enviropeel products are  
manufactured and  
distributed worldwide by  
A&E Group



[www.ae-sys.com](http://www.ae-sys.com)

# ENVIROPEEL SLUGGER 170 OPERATING INSTRUCTIONS

## IMPORTANT

The wires in the mains lead are coloured in accordance with the following code

**GREEN/YELLOW = EARTH/GROUND**  
**BLUE = NEUTRAL/RETURN**  
**BROWN = LIVE/HOT**

## ELECTRICAL SAFETY

**WARNING - THIS APPLIANCE MUST BE EARTHED**  
**ONLY AUTHORISED SERVICE PERSONNEL ARE PERMITTED TO WORK ON**  
**ELECTRICAL EQUIPMENT - SERVICE BY NON-ENVIROPEEL ENGINEERS**  
**WILL VOID WARRANTY**

The colours of the wires in this mains lead may not correspond with the coloured markings identifying the terminals in your plug, if the plug needs replacement proceed as follows:

- The green and yellow wire is the EARTH/GROUND and must be connected to the terminal in the plug which is marked with the letter E or with an earth symbol or colored green & yellow or colored green on a US 3-pin plug.
- The blue wire is the NEUTRAL or RETURN and must be connected to the terminal which is marked with the letter N or colored black or colored silver on a US 3-pin plug
- The brown wire is LIVE/HOT and must be connected to the terminal which is marked with the letter L or colored red or colored gold on a US 3-pin plug

**ANY MOULDED MAINS CONNECTOR THAT REQUIRES REMOVAL/REPLACEMENT MUST BE DESTROYED BY REMOVAL OF ANY FUSE AND FUSE CARRIER AND DISPOSED OF IMMEDIATELY, AS A PLUG WITH BARED WIRES IS HAZARDOUS IF ENGAGED IN A LIVE SOCKET**

## GENERAL SAFETY INSTRUCTIONS

Do not touch the nozzle or molten Enviropeel with bare skin as they are hot - the operating temperature of this unit is approximately 185°C/350°F. Protective gloves and glasses should always be worn. Careless handling can cause skin burns.

If molten Enviropeel comes into contact with the skin, immerse the affected area immediately in cold water. Seek medical advice if necessary. In addition to the safety instructions herein, any statutory regulations, local fire regulations, government agency, regulatory agency or other generally valid 'regulations for accident prevention' must be complied with when using this tool.

- Always inspect and clean unit prior to use - never use if damaged in any way.
- Do not use this unit whilst under the influence of drugs or alcohol.
- Do not use this unit in damp environments, outdoors while it is raining, or where there is unsatisfactory water separation from the compressor in high humidity areas.
- Do not use this unit in the vicinity of any heat sensitive materials, or any flammable materials, liquids, or gases.
- Only use extension cables with a wire cross section of at least 1.5 mm<sup>2</sup>/16 a.w.g. and no more than 20 m/65 ft in length.
- Never pull on the unit's connecting cable.

**SEE STEPS 1-5 ON PAGE 3 BEFORE CONNECTION TO THE MAINS SUPPLY**  
**WHEN USING THE APPLICATOR FOR THE FIRST TIME**

## WHEN USING THE APPLICATOR FOR THE FIRST TIME, STEPS 1-5 SHOULD BE FOLLOWED BEFORE CONNECTION TO THE MAINS SUPPLY.

- 1 Insert stand into grooves at base of handle. Stand unit on a flat surface.
- 2 Connect the air supply hose to a clean, dry and regulated air supply using the quick disconnect fittings provided. Use of a filter/regulator and water separator is mandatory.
- 3 Pull piston back fully and rotate upwards (see diagram below).
- 4 Load two Enviropeel slugs into barrel and push forward fully.
- 5 Rotate the piston down and slide forward fully until it contacts the rear of the Enviropeel slug. It should engage about 6-8 mm/ $\frac{1}{4}$  inch into the barrel.
- 6 Connect the unit to the mains electricity supply.
- 7 The red light will illuminate, indicating power supply on.
- 8  Wait 10-14 minutes to allow the heating chamber to reach operating temperature.

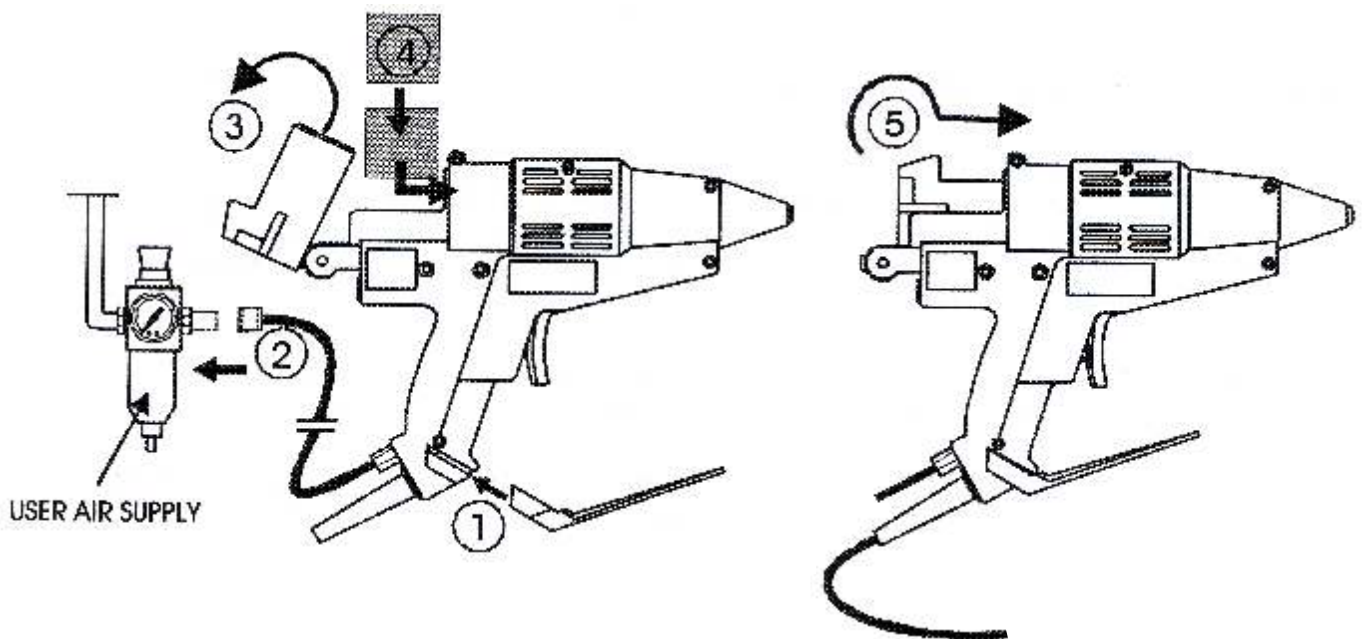

### APPLYING ENVIROPEEL - SPRAY ADJUSTMENT

Turn the spray air adjustment control completely clockwise. Hold the unit facing away from you and squeeze the trigger, a bead of Enviropeel will be extruded from the nozzle. While squeezing the trigger, turn the spray air control slowly anti-clockwise, the bead will turn into a spiral spray pattern. Continue to adjust the control until a suitable pattern is reached to suit your application. To stop the Enviropeel flow, simply release the trigger.

NOTE: Reload when the piston backplate touches the piston support arm. This will be indicated by a white line becoming visible on the piston support and the sound of air escaping. Pull the piston back and load an Enviropeel slug immediately.

## ENVIROPEEL FLOW RATE ADJUSTMENT

The flow rate of Enviropeel is adjusted by varying the air pressure to the drive piston. This is done by adjusting the pressure regulator at the main air supply line. Operating range MIN. 45 p.s.i. (3 bar) MAX. 105 p.s.i. (7 bar).

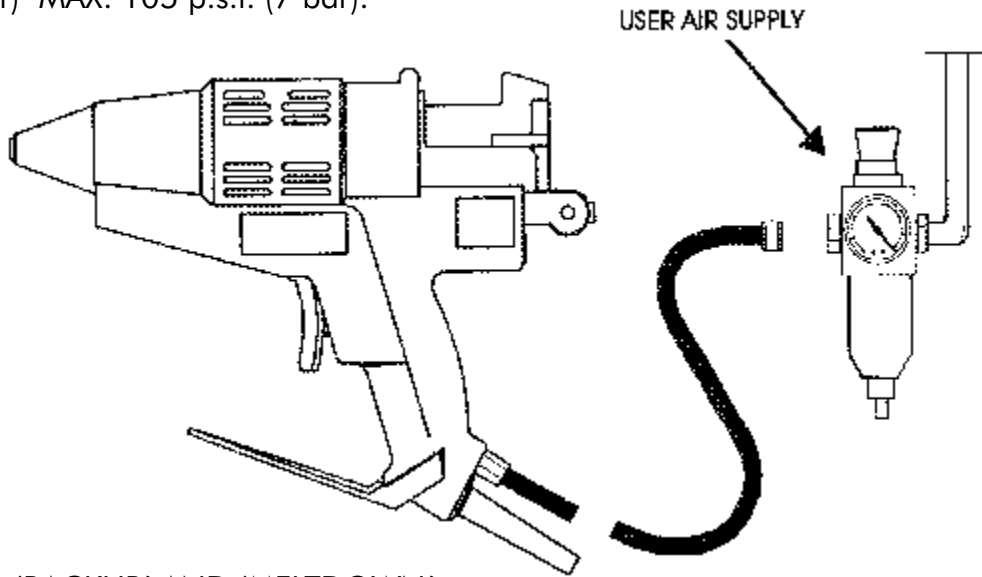

## AVOIDING 'BACKUP' AND 'MELTDOWN'

'Backup' is caused when hot molten Enviropeel is forced back between the barrel wall and the outside surface of the Enviropeel slug. 'Meltdown' is when the rear of the Enviropeel slug softens to the extent that it is not rigid enough to be driven forward without collapsing. In both cases, as the molten slug solidifies, it can lock the Enviropeel slug and/or the piston in the barrel.

This tool is fitted with a specially coated piston which has non-stick characteristics far superior to any PTFE coating; this minimises the effect of any backup that may occur.

Every attempt has been made to make this exceptionally powerful tool reliable and trouble free - to avoid problems, the following precautions should be noted.

- MAKE SURE THE UNIT IS UP TO TEMPERATURE BEFORE ATTEMPTING TO OPERATE
- DO NOT LEAVE THE UNIT SWITCHED ON FOR LONG PERIODS WITHOUT USE. IF THE UNIT IS NOT TO BE USED FOR FORTY MINUTES OR MORE, SWITCH OFF AND RESTART WHEN REQUIRED
- ONLY USE THE CORRECT ENVIROPEEL SLUGS IN THIS UNIT
- KEEP THE UNIT UPRIGHT WHEN NOT IN USE.
- ALWAYS USE THE STAND PROVIDED
- NEVER LAY THE UNIT ON ITS SIDE
- ALWAYS CLEAN UNIT AFTER USE
- DO NOT ALLOW OIL TO POOL WITHIN CHAMBER
- NEVER OPERATE TRIGGER WHEN PISTON/CHAMBER IS OPEN

**SERVICING & REPAIRS MUST ONLY BE CARRIED OUT BY QUALIFIED PERSONNEL  
RETURN THE SLUGGER TO YOUR SUPPLIER IF IT REQUIRES ATTENTION**



## Guarantee

This applicator is guaranteed against faulty workmanship, materials and malfunction for a period of 12 months from the date of purchase.

This guarantee does not apply:

If the applicator has been dropped, damaged due to careless handling or has not been used in accordance with the manufacturer's instructions.

If the applicator has been modified in any way.

If the applicator has been opened or the serial number removed or defaced or the electrical cable has been damaged or replaced.

If any materials other than Enviropeel have been used.

The manufacturer undertakes to repair or replace at their discretion. The tool will be returned carriage paid.

Seller's and Manufacturer's only obligation shall be to replace such quantity of the product proved to be defective. Neither seller or manufacturer shall be liable for any injury, loss or damage direct or consequential, arising out of the use or inability to use the product. User shall determine the suitability of the product for his intended use and the user assumes all risks and liability whatsoever in connection therewith.



[www.ae-sys.com](http://www.ae-sys.com)

*Enviropeel products are manufactured and distributed worldwide by A&E Group*

Contact your local A&E office for service:

### AUSTRALIA

A & E Systems PTY Ltd  
3/20 Clark Court, Bibra Lake,  
Perth WA 6163, Australia  
Tel: +61 (0)8 94183688  
Fax: +61 (0)8 94183588  
Email: [aus@ae-sys.com](mailto:aus@ae-sys.com)

### EUROPE

A & E Systems Ltd  
3 Charles Wood Road  
Dereham, NR19 1SX, UK  
Tel: +44 (0)1362 694915  
Fax: +44 (0)1362 695350  
Email: [uk@ae-sys.com](mailto:uk@ae-sys.com)

### MALAYSIA

A & E Systems Sdn Bhd  
No 37B, Jalan USJ 21/11  
UEP Subang Jaya,  
47600 Subang Jaya  
Selangor, Malaysia  
Tel: +60 (0)3 80246277  
Fax: +60 (0)3 80236090  
Email: [mal@ae-sys.com](mailto:mal@ae-sys.com)

### USA

A & E Anti-Corrosion  
Systems LLC  
150 Hilden Road,  
Ste #301, Ponte Vedra,  
Florida 32081, USA  
Tel: +1 904 819-8985  
Fax: +1 904 819-1430  
Email: [usa@ae-sys.com](mailto:usa@ae-sys.com)



## REPAIR / GUARANTEE CLAIM FORM

### IMPORTANT

Please complete the form below as comprehensively as possible as it will greatly aid us to complete an effective and prompt repair. **Do not send back** before reporting fault to your local service center below or by email to [techservices@ae-sys.com](mailto:techservices@ae-sys.com)

Returned unit must be properly packed, Enviropeel is not responsible for transit damage. All valid guarantee claims will be carried out free of charge (please see guarantee conditions). We will seek authorization prior to carrying out any chargeable work.

Date Purchased: \_\_\_\_\_ Product and ref: \_\_\_\_\_

Serial Number: \_\_\_\_\_ Where purchased: \_\_\_\_\_

Purchaser Name/Company: \_\_\_\_\_

Address: \_\_\_\_\_

City: \_\_\_\_\_ State/County/Province: \_\_\_\_\_

Zip/Postcode: \_\_\_\_\_ Country: \_\_\_\_\_

Tel (inc country & area code) : \_\_\_\_\_

Fax: \_\_\_\_\_ Email: \_\_\_\_\_

Nature of problem \_\_\_\_\_

\_\_\_\_\_

\_\_\_\_\_

\_\_\_\_\_

*Send to your local service center address:*

#### AUSTRALIA

A & E Systems PTY Ltd  
3/20 Clark Court, Bibra Lake,  
Perth WA 6163, Australia  
Tel: +61 (0)8 94183688  
Fax: +61 (0)8 94183588  
Email: [aus@ae-sys.com](mailto:aus@ae-sys.com)

#### EUROPE

A & E Systems Ltd  
3 Charles Wood Road  
Dereham, NR19 1SX, UK  
Tel: +44 (0)1362 694915  
Fax: +44 (0)1362 695350  
Email: [uk@ae-sys.com](mailto:uk@ae-sys.com)

#### MALAYSIA

A & E Systems Sdn Bhd  
No 37B, Jalan USJ 21/11  
UEP Subang Jaya,  
47600 Subang Jaya  
Selangor, Malaysia  
Tel: +60 (0)3 80246277  
Fax: +60 (0)3 80236090  
Email: [mal@ae-sys.com](mailto:mal@ae-sys.com)

#### USA

A & E Anti-Corrosion  
Systems LLC  
150 Hilden Road,  
Ste #301, Ponte Vedra,  
Florida 32081, USA  
Tel: +1 904 819-8985  
Fax: +1 904 819-1430  
Email: [usa@ae-sys.com](mailto:usa@ae-sys.com)